

## **Automation of Material Handling: Design & Analysis of Bucket System on an Inclined Rail**

**Abhilasha V. Dongre, Prof. N.Y.Mohite**

M.Tech Student, Dept. of Mechanical Engineering, Dr. Babasaheb Ambedkar college of Engineering and Research Nagpur, India

Lecturer in Dept. of Mechanical Engineering, Dr. Babasaheb Ambedkar college of Engineering and Research Nagpur, India

---

**Abstract:** Material handling systems are widely used in the industry for transportation of raw material, finished product, storage and retrieval of materials. The increase cost of labor and manual work or operation is now replaced by semiautomatic or automatic system. These low cost systems are not only cost efficient but also enhance productivity & address the issues related to labor problem. Material handling equipment is designed such that they make simple, economical, fast and safe loading and unloading with less human intervention. The research work is related to develop an automated material Handling system MHS in the chemical Industry where the bulk material transportation is done manually. The successful completion of this research work has generated design and analysis of an automated bucket on inclined rail system for the chemical industry, which is quick, efficient and safety to labor.

**Index Terms:** Bucket elevator, rail system, Material Handling equipment, loading, unloading, calibration, productivity, sensor, safety.

---

### **I. INTRODUCTION**

The main objective of the today's automation technology is productivity and flexibility, which can only be achieved in fully integrated manufacturing units. In this required integration a carefully designed and efficiently managed material handling system is crucial importance. Material handling is an important activity within the larger system by which materials are moved, stored, and tracked in our commercial infrastructure. Materials handling as such are not a production process and hence do not add to the value of the product. It also costs money; therefore it should be eliminated or at least reduced as much as possible. However, the important point in favor of materials handling is that it helps production. Depending on the weight, volume and throughput of materials, mechanical handling of materials may become unavoidable. Automated materials handling (AMH) refers to any automation that reduces or eliminates the need for humans to check-in, check-out, sorting material, material transfer and bins containing library material. To explain further varieties of automated material handling, mentioning about tools like cranes and hoist is significant as they move heavy loads. There are many types of automated cranes used these days like single girder, gantry cranes, and so on. These are manufactured keeping in mind the load capacity, gear boxes, electrical panes and motors. Wire rope electric hoist are also useful in factories or warehouses. Benefits of AMH systems include quicker material movement, lower inventories and storage space, reduced product damage and higher labor productivity.

### **II. LITERATURE REVIEW**

Julie Christopher, Michael E. Kuhl and Karl Hirschman [1] have shown the research utilizes two simulations of SEMATECH fab data of actual production fabs. As a critical aspect of semiconductor manufacturing is the design and analysis of material handling and production control policies to optimize fab performance. The hypothesis of this study is that both vehicle and machine dispatching rules and their interaction will have significant impact on fab performance. To test this hypothesis authors has performed full factorial design experiment. The vehicle and machine dispatching rules as well as their interaction are shown to have a significant impact.

[Jane C. Ammons](#) and [Leon F. McGinnis](#) [2] have discussed the advent of automation in manufacturing and warehousing, material handling is being seen as a focal point of total system integration and control. In contrast to mechanical design problems, this paper addresses current issues in the design and operation of material handling systems from an overall systems viewpoint. They reviewed topics which include automated storage and retrieval systems, order picking, order sortation and accumulation, and transportation. Their purpose is to overview essential issues, describe representative research, and identify critical needs for future study.

Vieira, G. B. B., Pasa, G. S., Borsa, M. B. N. O., Milan, G. S., Pandolfo, A. [3], They present the study focused on improvements in internal materials handling management, approaching the case of a large company

in the automotive industry. The objective of the research was to evaluate, in a systematic way, the impact of implemented changes in materials handling management on the internal customers' perceptions of cost, safety in service, service reliability, agility and overall satisfaction. In order to do this, they identify the factors that explain overall satisfaction; to do it, open-ended questionnaires were applied. Around 26 people who are directly linked to daily materials flow – were requested to identify the attributes and unfold them into sub-factors which represented the internal process in more details. The identified attributes were cost, safety in service, service reliability and agility. , a second questionnaire held to identify in order to evaluate performance satisfaction at each factor and sub-factor and also overall satisfaction. The collected data were analyzed with multiple regressions. Data analysis indicated that the factors agility, service reliability and cost are able to explain overall satisfaction. In addition to that the satisfaction level of most of internal customers with the new materials handling management system is equal or even superior when compared to the previous one.

Klotz T. [4], the author discussed the design of correctly implemented controls in material handling systems (MHS) is time consuming and cumbersome. For baggage handling systems (BHS) at airports, the error-free implementation of routing strategies is especially of importance, as these strategies are critical to safety. This paper proposes a compositional approach to the formal verification of routing in MHS. The approach is based on the theory of assume-guarantee reasoning, where proofs of the overall system are derived from proofs of subsystems. Moreover, the approach has been implemented in a tool that automatically carries out the verification. A real-world example is discussed in this paper, showing the benefits and scalability of the presented approach.

Johansson B. Williams E.J. Alenljung T. [5], this paper describes a modular autonomous material handling equipment solution for flexible automation. Discrete event simulation is in this case used as a tool for shortening time spent in many different phases of a manufacturing systems lifecycle. The paper presents the concept of autonomous modular material handling equipment, and how simulation is used as a support tool and lead time reducer in each lifecycle phase. They also describe the knowledge levels needed for using the simulation support and conclude with examples of how this methodology are reducing lead times within a company.

### **I. Problem Identified In The Company**

After visiting R.C Technofab Private limited company situated in Hingna, Nagpur. It provides mixing of different composition of chemical powder. The transfer of material loading, unloading and calibration is done manually. The problem identified is given below:

- To handle heavy bulk material is hazardous to workers.
- Weight calibration is manual and prone to error.
- Calibration error results in rejection of entire powder mix.
- Blending of powdered chemical is through hand and bucket system.
- Labor effort is more this cause high cost.
- Manual transfer of material takes more time.
- Space available is less.

After thorough study of process held in company and the literature survey under references help us to determine the best suitable way to increase productivity of the company by eliminating manual work and implementing automation of the material handling with rail and solenoid bucket to handle the material and calibrate the powder material.

### **III. RESEARCH METHODOLOGY**

According to related literature review, we have collected the required data and evaluate these result with experimentation perform on present work and analyses the result. The detailed study on chemical plant, reviewing literature under references, it is concluded that inclined rail with solenoid bucket is best suitable conveyor for the Plant. This problem can be discussed under following requirement.

(i) Path design / Route for conveyor (ii) Material handling Design Selection /Suitable method for support (iii) Maximum lift design load (iv) 3d Modeling (v) Analysis.

#### **A. DESIGN CONSIDERATIONS**

For handling purposes, materials can be classified by the physical characteristics such as liquid, solid & gas. In addition to material characteristics, other factors must be considered in determining which type of equipment is most appropriate for the application. These other factors include (1) quantities and flow rates of materials to be moved, (2) routing factors, and (3) scheduling of the moves. The amount or quantity of material to be moved affects the type of handling system that should be installed. As in this chemical industry material is transported in power form. Routing factors include pickup and drop-off locations, move distances, routing variations, and conditions that exist along the routes. Scheduling relates to the timing of each individual delivery. Depending on the form of the material, flow rate is measured in pieces/hr, pallet loads/hr, tons/hr, ft<sup>3</sup>/day, or similar units.

Plant layout is an important factor in the design of material handling system. When a new facility is being planned, the design of the handling system should be considered part of the layout. As the available space is not less so that we cannot use conveyor belt. There are following reasons for not using belt conveyor that (i) material is in powder form (ii) In powder form, risk of inhaling chemical due to exposed open conveyor. Positive dosing (perfectly calibrated amount) cannot be done through conveyor.

A bucket elevator, also called a grain leg, is a mechanism for hauling flow able bulk materials (most often grain or fertilizer) vertically. Single bucket elevator is fully suitable for loading and unloading purpose because it will take less space as compared to the belt conveyor and cost will also be manageable. There are two types of single bucket elevators one is vertical and another is inclined. Amongst these two we select the inclined single bucket elevator instead of vertical one because it enables the bucket to unload the material easily and torque required to pull the load will also be reduced.

Without guide ways in our proposed design of material handling system it is not possible to unload the material. Therefore our design of guide ways is done in such a way that it can not only transfer the material to the wet mixer but can also unload it automatically into it. Equilibrium of a bucket on an inclined plane however, if the inclination of the plane to the horizontal is more than the angle of repose, the body will move down the plane and an upward force will be required to prevent it from sliding down the plane as shown in Figure 1.

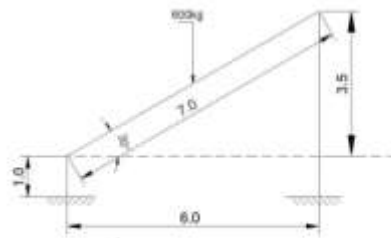

Fig. 4.1. Equilibrium of a body on an inclined plane

In limiting equilibrium,

$$\sum F_x = 0,$$

$$P + \mu R = W \sin \alpha$$

Or

$$\sum F_y = 0,$$

$$R - W \cos \alpha = 0$$

$$R = W \cos \alpha$$

Where,  $\alpha = 30^\circ$

As it is simply supported beam carrying load 600 kg as shown in Figure 1.

To Find  $R_A, R_B$

Reactions  $\sum F = R_A + R_B$

$$\sum F = 600 \times 9.81 \times \cos 30^\circ$$

$$R_A + R_B = 5097.2 \text{ N} \dots \dots \dots \text{Eq. 1} \quad \sum M_A = 0$$

$$\sum M_A = 0 + (600 \times 3.5) - (R_B \times 7) = 0$$

$$R_B = 2942.99 \text{ N} \dots \dots \dots \text{Eq. 2}$$

Put the value of  $R_B$  in Eq. 1

$$R_A + 2942.99 = 5097.42 \text{ N}$$

$$R_A = 2154.42 \text{ N}$$

Bending Moment at point A

$$A = 0$$

$$B = 0$$

$$m = 600 \text{ kg}$$

$$W = m \times g$$

Where m = mass

W = weight

L = length of the beam

At centre  $C = wl/4$

$$= 10,300.5 \text{ N}$$

The given Shear force and Bending Moment Diagram is shown in Figure. 4.2.

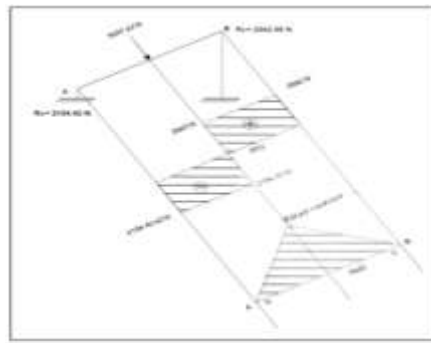

Fig.4.2 Shear force and Bending Moment Diagram

We have used a C section standard size beam of dimension 11m. To support that beam one square bar is jointed with it .

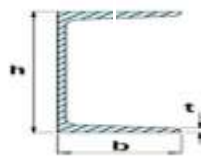

Fig. 4.3 Section of beam shape

Where , h = 150

B = 30

Design calculation for the bucket

As the shape of the bucket is truncated cone

$$\text{Volume } v = \frac{1}{3} \pi (r_1^2 + r_1 r_2 + r_2^2) h$$

$$\text{Lateral Area } F = \pi (r_1 + r_2) \sqrt{((r_1 - r_2)^2 + h^2)}$$

$$\text{Surface Area } S = F + \pi (r_1 + r_2)^2$$

lower radius  $r_1$  0.1

upper radius  $r_2$  0.25

height h 0.6

volume v 0.06126

lateral Area F 0.680039

Surface Area S 0.907804

All dimensions are in m.

$$(\text{Volume})_m = 0.06 \text{ m}^3$$

Weight of bucket is 880 N



Fig. 4.3 3D cad model of bucket with rollers

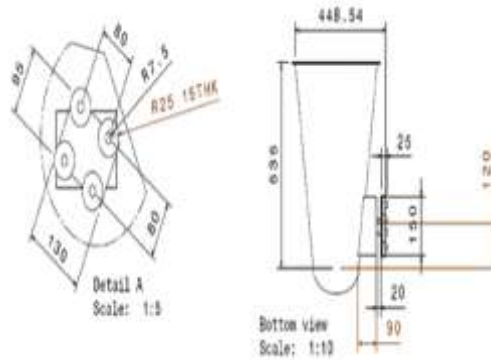

Fig. 4.4 2D structure of bucket with rollers

### B. Weight Calibration

Sensors that measure quantities such as weight and force have been a staple of industry electronics for many years. “Performance of force/weight sensors is one of the factors that influence the productivity and manufacturing cost in many industries”. The sensors are used to: “detect and measure a relative change in a force or applied load; detect and measure the rate of change in force; identify force thresholds and trigger appropriate actions; and, detect contact and/or touch”. For proper calibration of the weight sensor, a dead-weight test stand is normally used in order to reach accurate and repeatable sensor loading. The purpose of electronic weight sensor is used to calibrate the powder mix while loading in to the bucket shown in the Figure 5.



Fig.4.5. Electronic Weight Sensor

### C. Drive System

Worm drives are a compact means of substantially decreasing speed and increasing torque. Worm drives are used in presses, rolling mills, conveying engineering. Worm gears are used on many lift/elevator and escalator-drive applications due to their compact size and the non-reversibility of the gear.

Since the load to be lifted is 600 kg (450 kg of material, 88 kg of bucket and 62 kg miscellaneous) to the height of 5 meter in 30 seconds, therefore power required at machine is 1 KW.

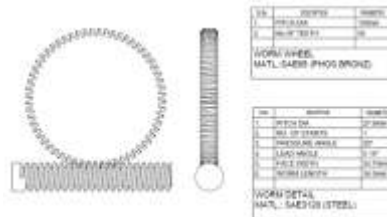

Fig.4.6. 2D-Structure of worm and worm wheel

### D. Electric Chain Motor

Motor is selected as 2 horse power capacity with 930 rpm proportions.

- Electric motor is coupled with gear unit with flange.
- The motor will have an electromagnetic brake which normally in the closed condition and when supply will be given then it used to open and permit motor to rotate.
- When supply is suddenly stop the brake is active itself.

### E. Contactor

Since our material handling system requirement is to way both sides that is up and down therefore motor has to rotate both the directions clockwise and anticlockwise. For this application the standard way is to use the contactor which enables motor to rotate both the direction whenever necessary.

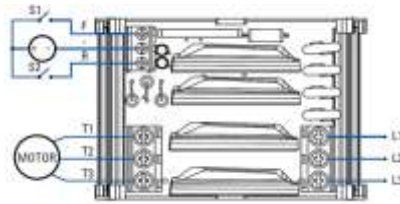

Fig. 4.6 Circuit diagram of contactor is shown.

**F. Limit Switch**

Limit switches, regardless of their final purpose, can only perform two functions. The switches either activate (turn on) or deactivate (turn off) an electrical circuit. Some of these switches are used in industry, and others are utilized for common household appliances.

**G. Assembly Diagram**

The diagram shows the assembly of bucket on an inclined rail.

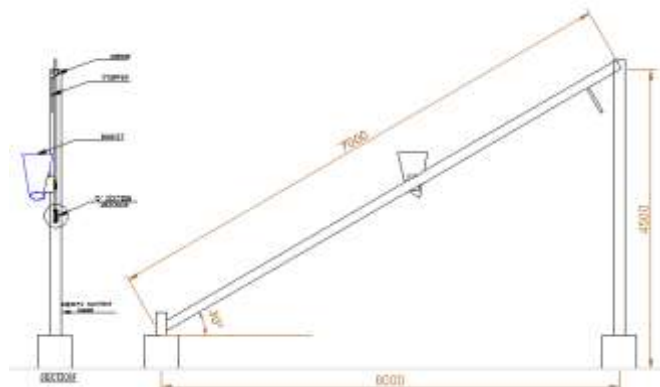

Fig.4.7. Assembly of bucket on an inclined Rail

**IV. ANALYSIS**

To innovate, get to market faster and improve reliability, successful manufacturing companies must simulate. Failure to invest in simulation could put organization at a serious competitive disadvantage. In this project Analysis us helps to validate design concepts early when it’s easy and inexpensive to make changes. The assembly of inclined rail and support structure is done in CATIA software and after that General Structural analysis is also done in CATIA Software. It not only saves design time and money but increase a design’s originality while reducing the risk of unexpected failure.



Fig. 5.1 Boundary Conditions and application of load

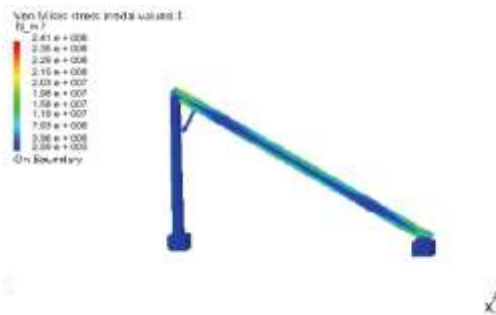

Fig. 5.2 General Von Mises maximum and minimum stress

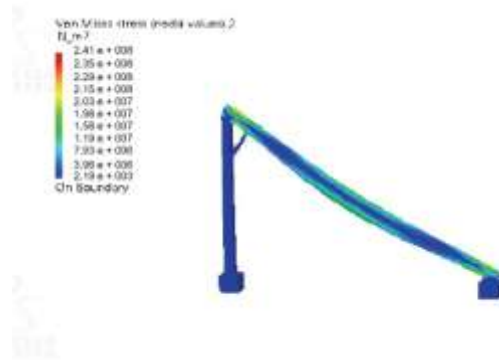

Fig. 5.3 Global Von Mises maximum and minimum stress

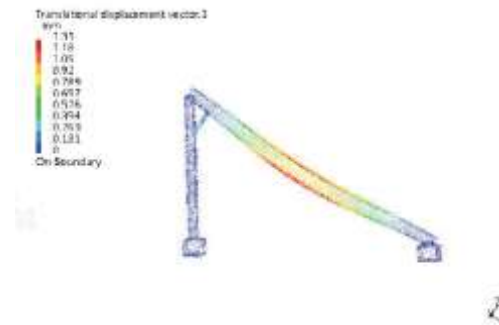

Fig. 5.4 Translational displacement

A simply supported beam with c section has been analyzed. Based on the type of loading that is point load and self weight the deflection and stress values have been measured. The computational analysis is done on CATIA V5R20 which is general purpose finite element analysis software and enables the product development process at less computational and financial expenditure. Many researchers have used this software for the validation of their experimental. The analytical calculation of beam has been also done below.

1. Calculation for Bending Stress & Deflection for Simply Supported Beam

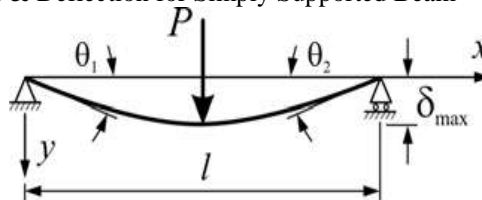

Fig. 5.5 Simply Supported Beam at Ends – Concentrated load P at the center

For Bending Equation

$$\frac{M}{I} = \frac{\sigma}{y} = \frac{E}{R}$$

a) Bending Stress  $\sigma_b = 224 \text{ MPa}$

b) Maximum Deflection at centre

$$y_{max} = -\frac{Wl^3}{48EI}$$

Maximum Deflection = -0.0610 m

Note: Negative sign for slope at A indicates that the rotation is clockwise and negative sign for deflation at centre indicates that the deflection is in downward direction.



c) Slope ,  $\Theta_1 = \Theta_2$  at the ends =  
 $\Theta_1 = -1.499^\circ$   
 $\Theta_2 = 1.499^\circ$

### V. RESULT & CONCLUSION

| Sr. No. | Simply Supported Beam of C Section                              | Analytical | Computational | Error with (%) |
|---------|---|------------|---------------|----------------|
| 1.      | Single Load + Self Weight<br>Maximum Stress in N/m <sup>2</sup> | 2.24 E+008 | 2.41 E+008    | 0.654          |
| 2.      | Single Load + Self Weight<br>Maximum Deflection in m            | 0.0610     | .00131        | 0.059          |

Table 6.1 Comparison of Result

Table 6.1 gives the comparison of analytical results with the computational results. The analytical results for loading condition have been compared with computational results considering the most universally used elements i.e. Ten node TE10 Tetrahedral element. The can be calculated that the analytical computed results are somewhat matching with the computation values while using CATIA V5R20. It has been also noted that in case of deflection the element TE10 node gives a closer value in all types of loading.

The result shows the maximum stress value 2.41 E+008 N/m<sup>2</sup> is less than the yield strength of the material 2.50 E+008 N/m<sup>2</sup> of structural C section. The computation displacement also shows that for the length of 7 m the displacement is .00131m is matching with the analytical result. Thus the result confirms that stress analysis is essential to determine the values when beam is loaded. Hence, from the above results we find that the design made for the application is acceptable and safe. The structure is safe because the stress magnitude which was obtained from the analysis is less than the yield strength of the structural material. Factor of safety for the rail system is 1.54 which is less than the design factor of the rail.

### VI. ACKNOWLEDGEMENT

We are very grateful to the many industrial persons, who provide us related data and example. We also appreciate our research scholars, friends and family for their contribution. Special thanks to our honorable teachers and guides because of their valuable knowledge and cooperation makes us able to complete the project.

### REFERENCES

- [1] Julie Christopher, Michael E. Kuhl, Karl Hirschman, "Simulation Analysis of Dispatching Rules for Automated Material Handling Systems and Processing Tools in Semiconductor Fabs," 0-7803-9144-6/05/\$20.00 ©2005 IEEE.
- [2] [Jane C. Ammons](#) and [Leon F. McGinnis](#) G, "Advanced Material Handling," Appl. Mech. Rev 39(9), 1350-1355 (Sep 01, 1986) Online June 12, 2009.
- [3] Vieira, G. B. B., Pasa, G. S., Borsa, M. B. N. O., Milan, G. S., Pandolfo, A., "Materials Handling Management: a Case Study" Journal of Operations and Supply Chain Management 4 (2), pp 19 - 30
- [4] Klotz T., "Automated Formal Verification of Routing in material Handling systems," Automation Science and Engineering, IEEE Transactions on Volume:10 , Issue: 4.
- [5] Johansson B. Williams E.J. Alenljung T., "Using Autonomous Modular Material Handling Equipment For Manufacturing Flexibility," Dept. of Product & Production Dev., Chalmers Univ. of Technol., Gothenburg, Simulation Conference ,2004, proceeding of 2004 winter, Volume 2.
- [6] Mikell P. Groover. "Automation, Production System and Computer-Integrated Manufacturing. PHI Learning Private Limited Third Edition pp. 1-15, pp.296
- [7] Gearology, Worm and Worm gears SNU pp. 44-60
- [8] "Design Data" Data Book of Engineers Compiled by PSG College of Technology Apple, J.A., "Material Handling System Design", John Wiley & Sons
- [9] Bulk Material Transfer Point Simulation of Material Flow Using DEM by Grzegorz Dewicki and Graham Mustoe Presented at Third International Conference on DEMs Sante Fe, New Mexico, September 23-25, 2002.